

# 37000 Series

## Vector Network Analyzer

Application Note

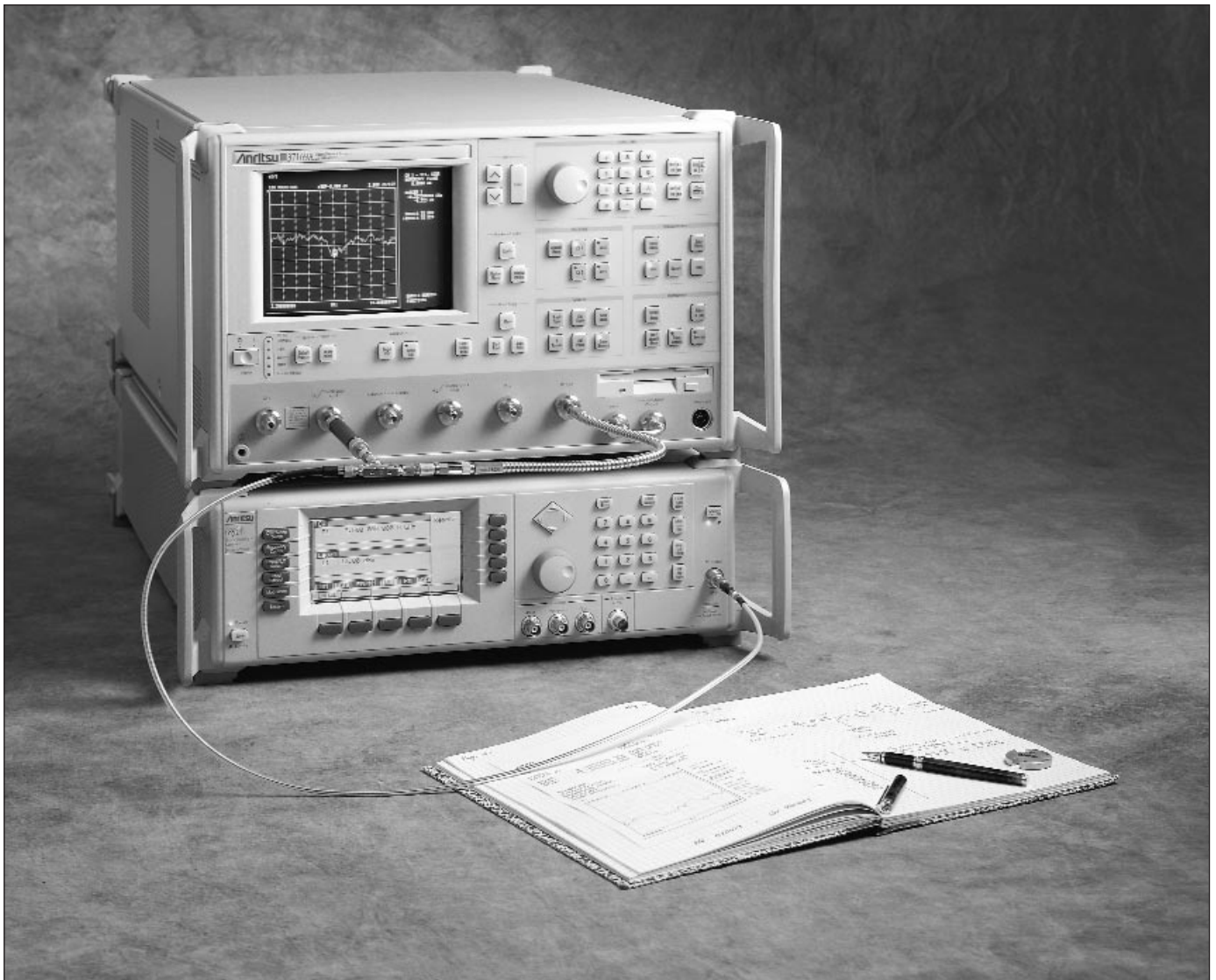

*Measuring Frequency Conversion Devices*

## Introduction

This application note discusses frequency conversion device measurements with the Anritsu 37100A Vector Network Analyzer. The 37200B and 37300A VNAs will also make these measurements, in addition to full S-parameter measurements. Appendix F shows how to apply the material presented on the 37100A to the 372/300 series. The mixer, a typical frequency conversion device, will be used as the DUT. However, everything covered is also valid for other frequency conversion devices such as up or down converters, multipliers, and dividers.

The measurements that will be discussed are the following:

- Amplitude and Phase Tracking
- Group Delay
- Port Match
- Port to Port Isolation
- Conversion Gain/Loss

For absolute conversion loss, magnitude and phase, Appendix E discusses the NxN mixer measurement method. This powerful technique that yields real time tuning capability, takes advantage of a special VNA calibrating software.

## MULTIPLE SOURCE CONTROL

Vector Network Analyzers are instruments used typically to make ratio measurements at the same input and output frequency. The Anritsu 37100A Direct-Access Receiver configuration is ideal for measuring frequency conversion devices. The 37100A uses its Multiple Source Control Mode to stimulate a frequency conversion device at one frequency, and measure its response at another.

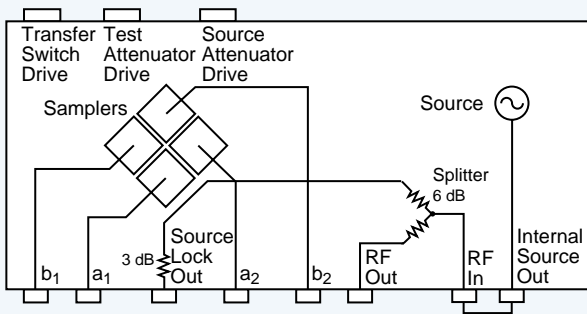

**Figure 1.** 37100A Direct-Access Receiver Configuration

Multiple Source Control allows the user to separately control up to two sources and a synchronously tuned receiver. The sources' frequency range and power along with the receiver's frequency range and reference channel may be specified. With the Multiple Source Control software, a sweep may consist of up to five consecutive bands, each with independent source and receiver settings for convenient testing of frequency conversion devices.

## Controllable Sources:

**Source #1:** Internal source or external Anritsu 68B, 69A, or 6700B series synthesizer.

**Source #2:** Any Anritsu 68B, 69A, or 6700B series synthesizer.

## Control Formula:

Multiple Source Control is specified as a frequency range partitioned into 1 to 5 consecutive bands. For each band, the sources' and receiver's frequency sweeps may be independently specified per the following formula. A CW frequency could also be specified.

$$\text{Frequency Sweep} = X/Y * (F + N \text{ (GHz)}), \text{ where}$$

N is the offset frequency in GHz  
F is the displayed frequency  
X, Y are integer constants

X, Y, and N may be independently specified for each source and receiver. They may be positive or negative numbers depending on the type of device. F is global and is the same value in all formulas.

**Example:** Band 1 = 500 MHz to 900 MHz

$$\text{Source 1} = 2/3 * (\text{CW } 1 \text{ GHz})$$

666.7 MHz CW

$$\text{Source 2} = 2/3 * (F - 0 \text{ GHz})$$

Will sweep 333.3 MHz to 600 MHz

$$\text{Receiver} = -2/3 * (F - 1 \text{ GHz})$$

Will sweep 333.3 MHz to 66.7 MHz

The x-axis will display the band of 500 to 900 GHz.

(Notice how the receiver is set to decrease in frequency with respect to the increasing band 1 frequency.) Check menus in Figure 2.

## Bands:

The specified frequency range may be divided into one to five bands. Band 1 must start at the beginning of the desired frequency range and end at a user-specified stop frequency or the end of the desired frequency range. Band 2 must begin at the next point after band 1 and continue until a user-specified stop frequency or the end of the desired frequency range, etc. Band 5 must end at the end of the desired frequency range. The unique ability of the 37100A's Multiple Source Control to divide the frequency range into bands makes it ideal for testing harmonic conversion devices.

Multiple Source Control comes with easy to follow menus containing helpful instructions. (Figure 2)

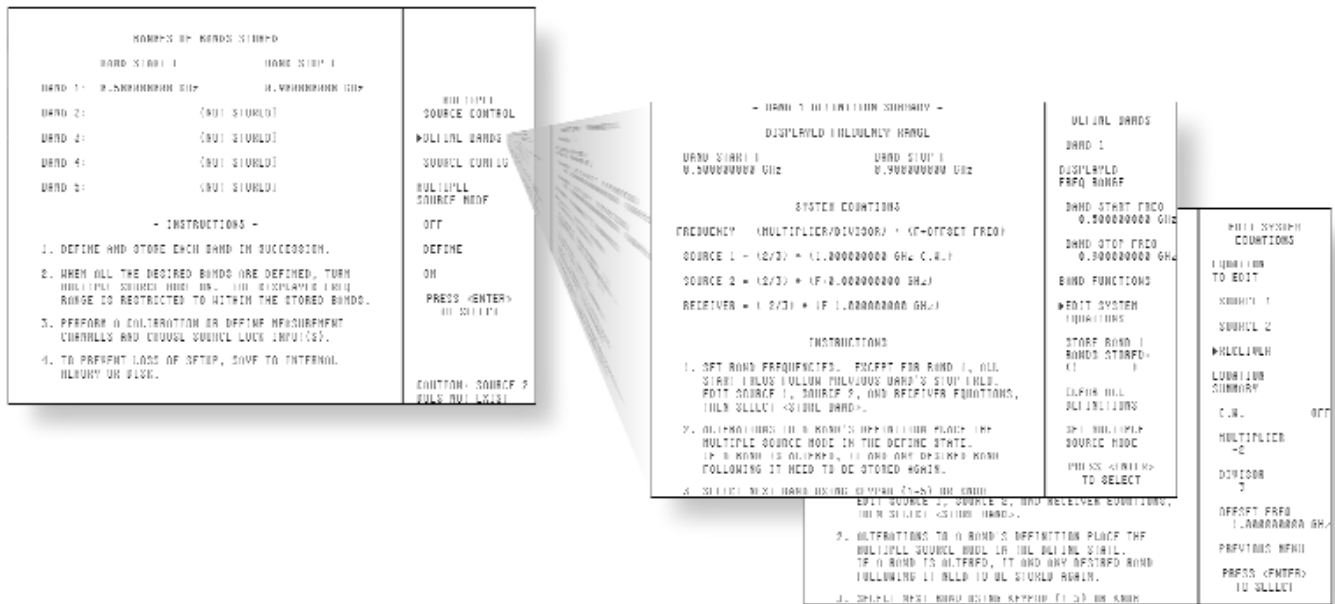

Figure 2. Multiple Source Control Menus

## AMPLITUDE AND PHASE TRACKING

Amplitude and phase tracking can be accomplished in one of two ways:

- Using a separate device as the phase lock reference.
- Using one channel of the DUT as the phase lock reference.

For mixers or other single channel devices, a separate device can be dedicated as the phase lock reference. Figure 3 shows a typical mixer amplitude/phase match configuration capable of operating from 10 MHz to 40 GHz. With the addition of a multiplier, millimeter-wave harmonic mixers can also be tested. The measurement system consists of an Anritsu 37169A VNA with Multiple Source Control capability, the internal source to provide the RF input and a synthesizer to provide the LO drive. The LO and RF are each split and applied to the DUT and reference mixers. 3 dB pads are used at every mixer port to improve the mixer match. Without these pads the standing waves on the interconnect cables can significantly affect the measurement. The IF outputs of the DUT and reference mixer are applied to a test and reference input on the 37100A. Filters at the receiver inputs will eliminate the possibility of errors due to spurs (see Appendix C on spurious response). The reference mixer is used to provide a signal for phase-locking the receiver and to provide a stable amplitude and phase reference.

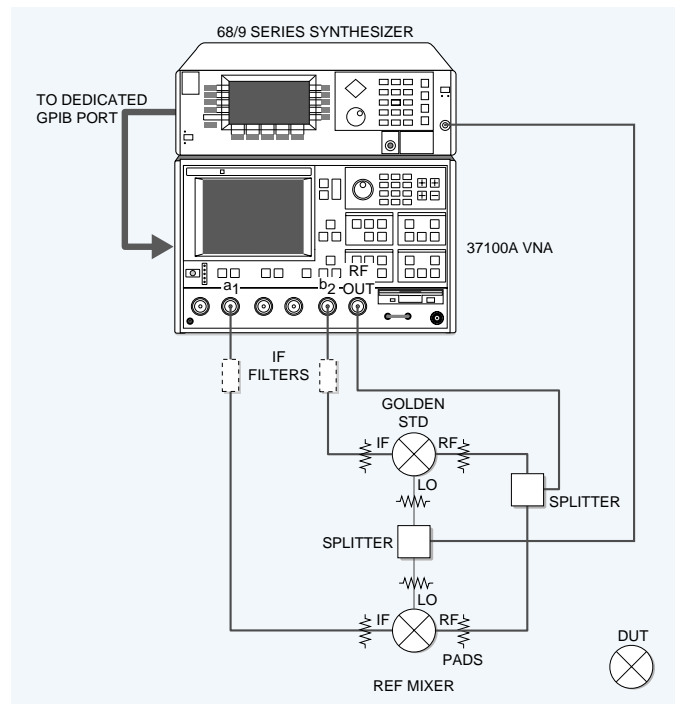

Figure 3. Mixer Amplitude and Phase Tracking Configuration

To amplitude and phase track the DUT mixers, the first one is connected. Multiple Source Control is used for setting the RF, LO, and Receiver frequencies. The first mixer's response is stored using the 37100A's trace memory feature. Successive mixers are then connected and compared to the first one. Up to three DUT's can be tested on one setup using four way splitters and the four input channels of the 37100A, one channel as a reference and the other three channels as test channels.

In many cases it is impractical to dedicate a separate device as a reference. This is true when testing multi-channel converters. Consider a two channel converter as shown in Figure 4. In an ideal, perfectly matched measurement system, the only contributor to gain/phase mismatch is the DUT. In a real system, however, mismatch can also be caused by the power splitter and its associated cabling, and by the receiver and its associated cabling. The source and its associated cabling do not contribute to the mismatch because they are common to both channels. In this system it is necessary to remove the effects of amplitude and phase mismatch in the test system channels. This can be accomplished in two ways, described in Appendix D.

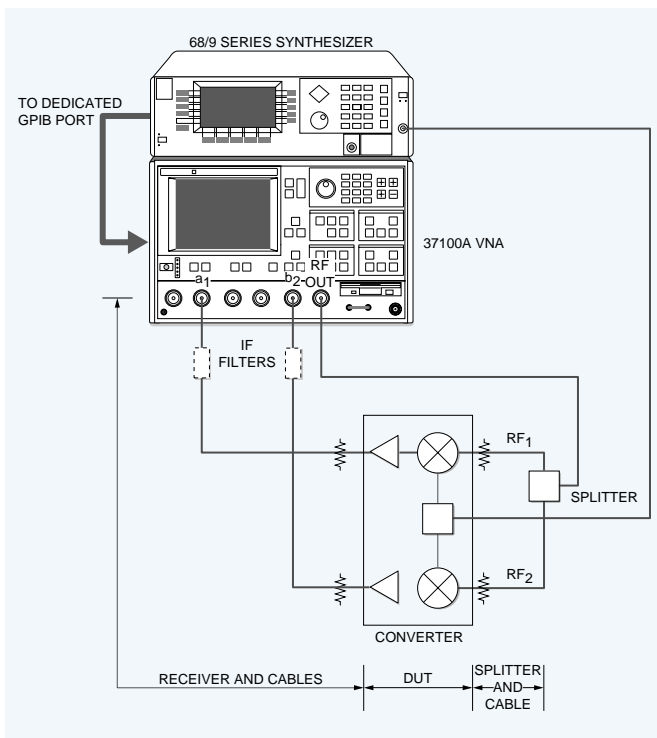

Figure 4. Measuring a Two Channel Converter

## GROUP DELAY

Group delay is the rate of change of phase through a device with respect to frequency. Measuring phase requires a reference plane, which cannot be directly established during a frequency translated measurement. Linear applications would use a through connection as a reference standard. The 37100A uses the approximation of a broadband mixer for the reference standard. This technique introduces a small measurement error, proportional to the broadband mixer's very small delay.

To measure group delay with a 37100A, follow the previous procedure for measuring amplitude and phase tracking. Use a broadband mixer as the first mixer, and store its group delay response in trace memory. Replace this reference setting broadband mixer with the device under test, and measure its group delay by looking at Data/Memory. Notice that all errors due to the phase locking mixer are in common mode, thus subtracted. The only remaining error is the small group delay of the broadband mixer used.

## PORT REFLECTION COEFFICIENT

Mixer port reflection coefficient can be measured by inserting couplers between the port to be tested and the source, as shown in Figure 5. With this configuration, the 37100A acts as a reflectometer, ratioing  $b_1/a_1$ . The receiver is set to the same frequency as the RF input. Port reflection coefficient can then be measured on the 37100A VNA as a normal reflection measurement.

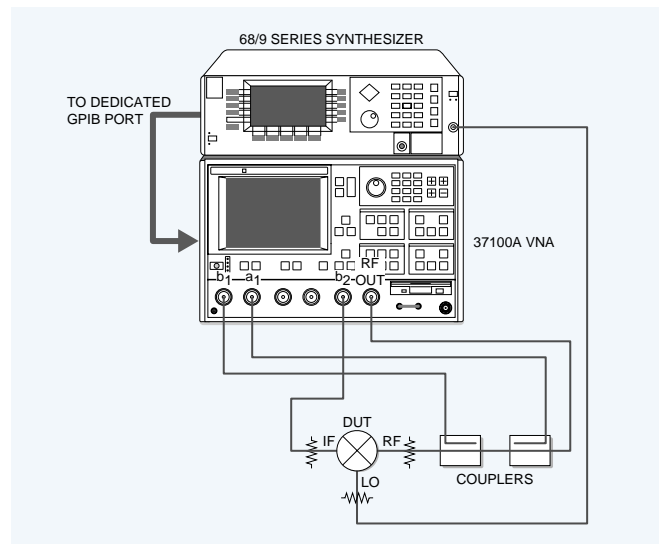

Figure 5. Setup for Measuring Port Match

Since the couplers are connected to  $b_1$  and  $a_1$ , the 37100A can be calibrated using a standard Reflection Only cal, or a 1 path 2 port cal. Notice that the receiver frequency was set to the same frequency as the RF input, simulating a non-frequency translated measurement. The calibration should be performed with the attenuators installed, to compensate for their effect.

## PORT TO PORT ISOLATION

RF to IF isolation, or LO to IF isolation can be measured using the same configuration shown in Figure 5. The receiver is again set to the same frequency as the RF input. RF to IF isolation is measured by ratioing  $b_2/a_1$ . If the couplers are placed in the LO port and the receiver is set to the LO frequency, then LO to IF isolation can be measured.

The 37100A can be calibrated for RF to IF isolation using either a frequency response or 1 path, 2 port calibration. Note that if a 1 path, 2 port calibration is used, the 37100A can measure port match and port to port isolation simultaneously.

## CONVERSION LOSS/GAIN

Measuring Conversion Loss is distinctly different from the previous measurements in that the VNA is not being used in its basic mode of making ratioed measurements. To measure Conversion Loss, the VNA needs to make absolute power measurements. This is accomplished by performing a flat test port power VNA calibration, using a power meter. (Appendix B)

The setup for measuring conversion loss is shown in Figure 6. First the receiver of the VNA needs to be calibrated to measure power at the IF frequency of the mixer. This is accomplished by connecting all the cables and components to be used in the final measurement, except for the mixer itself. The resultant measurement ( $a_1/1$ ) is stored in trace memory. Next, the internal source is calibrated for flat test port output power at the same power level as the IF, but at the RF frequency. Using Multiple Source Control and inserting the DUT in the chain, absolute Conversion loss can be measured by looking at data/memory.

A reference mixer is not necessary in measuring conversion loss or gain, eliminating the need for two power splitters. The  $a_1$  or  $a_2$  channels should be used to make the measurements. Either channel could be simultaneously used for locking and measuring purposes.

The 37100A has a phase lock RF output as shown in Figure 1. It is important to be consistent with the usage of this output throughout the measurement. If the source lock output is terminated during the receiver cal step and left open during the measurement step, differences in reflection will alter the results, making it meaningless. All aspects other than the mixer itself have to be in common between the trace in memory and data measured.

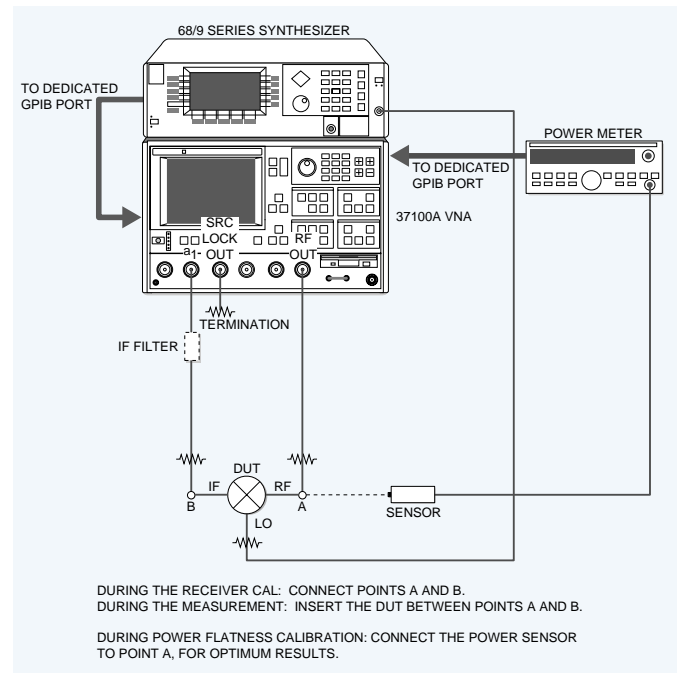

Figure 6. Conversion Gain/Loss Setup

## Conversion Loss Measurement Steps:

- ```
[Channel Menu]
  ▶ Single Channel      [Enter]
    [Graph Type]
  ▶ Log Magnitude      [Enter]
    [S Params]
  ▶ S21, Fwd Trans      [1]
    to redefine parameter,
    a parameter other than S21 could be chosen
  ▶ S21, User 1          [Enter]
    toggles to User 1
  ▶ Change Ratio        [Enter]
  ▶ numerator, a1       [Enter]
    a2 channel could be chosen
  ▶ denominator, 1      [Enter]
    notice display changes to a1/1
  ▶ Previous Menu       [Enter]
    phase lock is already on a1
  ▶ Previous Menu       [Enter]
```

### Calibrate the Receiver:

This is a direct function of the IF frequency; fixed or swept. A key point to remember is to maintain the number of data points consistent throughout the measurement. The VNA makes measurements at distinct frequencies. If the number of points varies between the stored and current traces, the VNA will not be able to make comparison calculations.

[Data Points]

▶ 401 max Points [Enter]  
*for example*

- Calibrate for flatness per Appendix B.

The start and stop frequencies should be a narrow band around the CW IF frequency, or the true band for a Swept IF frequency mixer.

The power levels should be adjusted for the mixer and setup. For best results, the test port where the flat output power is calibrated should be chosen to be at the output of the RF side pad (check Figure 6). For example, if the mixer conversion loss is chosen to be measured at 2 dBm, and a 3 dB pad is used at the RF input, the VNA Power Control and Port 1 Attn should be set for 5 dBm source output power. But in the Flatness Calibration menu, the Power Target should be adjusted to 2 dBm, compensating for the pad.

- Connect the through path between the RF and  $a_1$  channel including all cables, pads and filters, but without the mixer.
  - In case of a Swept IF mixer you are set for storing the response; proceed to [Trace Memory].
  - For a Fixed IF mixer, change the frequency mode to CW Mode per the instructions below, then proceed.

[Setup Menu]

▶ CW Mode [Enter]  
[IF Freq] [MHz]

[Data Points]

[401] [x1]

[Trace Memory]

▶ Store Data to Memory [Enter]  
▶ View Data / Memory [Enter]

### Measure Conversion Loss:

The start and stop frequencies should be adjusted for the RF band. The power level should be exactly the same as during the IF Calibration.

- Re-connect the power sensor to exactly the same test port as during the receiver calibration.
- Calibrate for Flatness per Appendix B.

You are now ready to insert the mixer and measure conversion loss.

- Put the VNA in Multiple Source Control Mode per Appendix A, properly setting the LO source power.
- Connect the Mixer following the Figure 7 setup and measure Conversion Loss directly.

## Summary

The Anritsu 37100A VNA is a powerful network measurement tool capable of measuring amplitude and phase characteristics on a wide variety of networks. This capability is not limited to devices with the same input and output frequencies. With the 37100A's direct-access receiver configuration and built-in Multiple Source Control, this capability is extended to frequency conversion devices as well. Devices such as mixers, up/down converters, frequency multipliers and frequency dividers can be measured with the 37100A VNA.

Gain and phase matching between devices, as well as port match and port to port isolation are readily measured by the Anritsu 37100A VNA. With the addition of a power meter for calibration, conversion loss can also be measured with the Anritsu 37100A VNA.

Included in the appendix is a description of absolute mixer measurements without reference to a "golden" standard. Appendix E describes the NxN technique. Notice that a full capability VNA is used instead of the Direct Access Receiver configuration. The external test set required is fully customized to each application. Please forward further interests on the NxN technique or any other VNA measurements requirement to you local Anritsu Wiltron representative.

## APPENDIX A: Multiple Source Control's Detailed Instructions

Notice the helpful instructions available in the various Multiple Source Control Menus. (Check Figure 2)

- Connect the external source to the dedicated GPIB connector of the VNA, making sure that the source GPIB address matches the VNA setting. Check by pressing [Option Menu] and selecting ★Source Config. The Source Config menu can also be accessed through the Multiple Source Control and the Receiver Mode menus found by pressing the [Option Menu] button.

[Setup Menu]

▶ Source 2 Pwr      ▶ Test Signals      [Enter]  
                                                                                  [Pwr Lvl]      [x1]

[Option Menu]

▶ Multiple Source Control

▶ Define Bands      [Enter]  
 ▶ Band      [1]  
 ▶ Band Start Freq      [Freq]      [GHz]  
 ▶ Band Stop Freq      [Freq]      [GHz]

▶ Edit System Equations      [Enter]

▶ Source 1      [Enter]  
 ▶ Multiplier      [#]      [x1]  
 ▶ Divisor      [#]      [x1]  
 ▶ Offset Frequency      [Freq]      [GHz]

• Repeat for Source 2

▶ Receiver  
 ▶ CW      [Enter]

*toggles ON*

▶ Offset Frequency      [Freq]      [GHz]

▶ Store Band 1      [Enter]

▶ Band      [2 thru 5]

▶ Previous Menu      [Enter]

*when done*

▶ Store Band      [Enter]  
*store each band independently*

▶ Set Multiple Source Mode      [Enter]      [Enter]

▶ ON      [Enter]

The default multiplier, divider, and offset frequency are 1, 1, and 0 respectively. Modify them as required making the source or receiver frequency a linear function of the band frequency. Notice that all inputs can be negative numbers depending on the application.

Up to five consecutive bands could be added, within which the three equations could be different. Notice that once a new band is entered, the Start Frequency is automatically set to the Stop Frequency of the previous band.

Before setting Multiple Source Mode ON, you may cycle through all stored bands, and easily verify the band frequencies and their equations on your screen.

Notice that the x-axis of the display during Multiple Source Control reads the raw band frequency, even though the receiver could be a CW frequency or a function of the band frequency. This is necessary to meet all possible applications of this extremely flexible tool.

## APPENDIX B: Power Flatness Calibration

Flat Power Calibration adjusts the source output power at each measurement point across a frequency span to provide a constant power level at the test port. For easy referral, these instructions along with additional recommendations are displayed in the Calibrate for Flatness menu. (Check Figure 7)

### Power Flatness Calibration Steps: (Check Figure 6)

- Preset, zero, and calibrate the power meter.
- Set power meter offset if required.
- Connect the power meter to the dedicated GPIB interface, and the power sensor to the test port.

[Setup Menu]

|                          |                    |       |
|--------------------------|--------------------|-------|
| ▶ Start                  | [Freq]             | [GHz] |
| ▶ Stop                   | [Freq]             | [GHz] |
| ▶ Test Signal            | [Enter]            |       |
| ▶ Power Control          | [Atten./Gain]      | [x1]  |
| ▶ Port 1 Attn            | [#] of 10 dB steps |       |
| ▶ Calibrate for Flatness | [Enter]            |       |
| ▶ 401 Points             | [1]                | [x1]  |
| ▶ Power Target           | [Pwr Lvl]          | [x1]  |
| ▶ Start Flat Power Cal   | [Enter]            |       |

The menu selection 401 Points will change depending on the data points per sweep selected. For a 401 frequency point sweep, at the default of a power point cal for every 1 frequency point, the outcome is a 401 points power calibration. This would result in the best performance, at the expense of the longest calibration time. If interpolation between frequency points is acceptable, change the # of frequency points interval for every power point calibration.

**Example:** 2001 frequency points per sweep, # of frequency points interval for a power point cal selected 20, results in 100 (2001/20) power points calibration.

Notice that the designation under “Calibrate for Flatness” changed from (No Cal Exists) to (Cal Exists). Also the “Flatness Correction” flag was set to ON. If desired this could be toggled to OFF. The calibration will remain stored for later use, until power is cycled. The calibration can be stored more permanently via the [Save/Recall Menu].

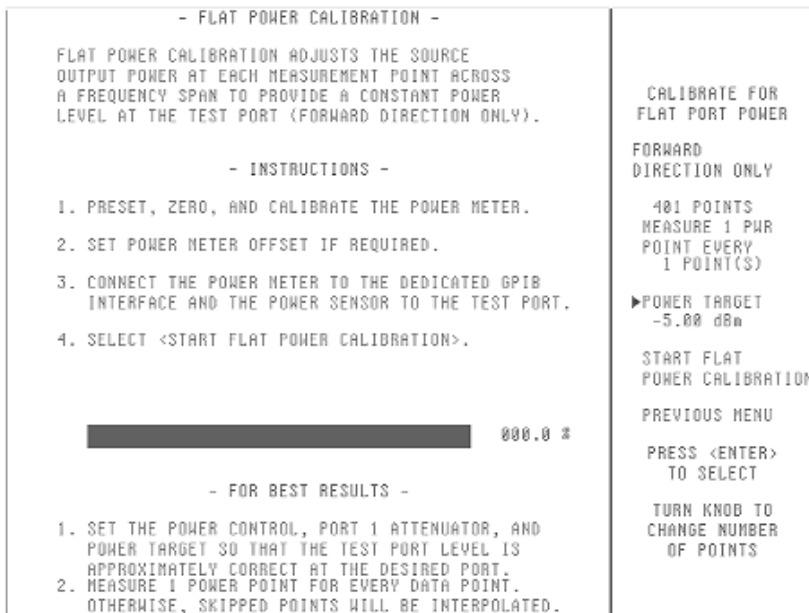

Figure 7. Calibrate for Flatness Menu.



## APPENDIX C: Errors Due to Spurious Signals

The 37100A's test set is a narrow band tuned receiver. As such, it is resistant to effects of spurious signals. However, there are times when the measurement can be affected or even destroyed by spurious signals. If a spurious signal is generated which is the same frequency as the IF frequency, it will affect the measurement.

Spurious signals in a frequency conversion device measurement are primarily caused by three sources:

- Mixer multiple IF's
- Mixer/37100A sampler mixed products
- Source frequency errors

### Mixer Multiple IF's:

With specific LO and RF combinations, a mixer can actually generate two IF's at the same frequency. For example, if a mixer receives an LO at 15 GHz and an RF at 10 GHz, it will produce an IF at 5 GHz. However, the second harmonic of the RF at 20 GHz will also mix with the LO and produce an IF at 5 GHz. Hence the 37100A would receive two IF's at the same frequency.

This is strictly a DUT phenomenon, independent of the receiver. The only way to avoid this problem is to select different frequencies. On the 37100A this can readily be accomplished using the Multiple Source Control's bands. The LO and IF can be normally defined until the problem frequency is approached. Then, using the next band definition, the LO and IF frequencies can be shifted slightly. (Enough to avoid the problem, but not enough to significantly affect the desired data.) After the problem frequency is passed, the LO and IF frequencies can, using a third band definition, be changed back to their original numbers.

### DUT/37100A Sampler Mixed Product:

The 37100A Test Set, above 270 MHz, has a sampler based front-end with a first LO of approximately 500 MHz. In normal operation, the sampler produces harmonics of the 500 MHz LO, one of which mixes with the incoming RF signal to produce the proper IF frequency. In a non-frequency translation measurement, there is only one RF frequency to mix with the signal. (The 37100A uses a unique "spur avoidance" algorithm to prevent harmonics of the input from mixing to the fundamental IF frequency.) In a frequency conversion measurement, there are spurious signals, such as the RF and LO leakage, which can mix with harmonics of the sampler to produce a spurious IF at the fundamental IF frequency. If this occurs, the measurement accuracy will be compromised. A measurement point affected by a spurious IF should be easily recognized, because that point will be significantly different than surrounding points.

To avoid the potential for sampler mixed products, the spurious signals from the DUT must be removed. This can be accomplished with filters at the receiver input. If, for some reason, filters cannot be used, the ability of the 37100A's Multiple Source Control to select bands can be used to avoid the spur. As previously described, when the bad point is reached, the LO can be shifted slightly (enough to shift the spur out of the IF range, but not enough to significantly affect the measurement). After the bad point, the LO can be shifted back to its proper frequency. The 37100A test set has a unique architecture which directly measures signals below 270 MHz, bypassing the sampler.

For many measurements it is feasible to keep the IF below 270 MHz. If the IF is kept below 270 MHz the sampler is not in the measurement path and potential problems from sampler spurs will not occur.

### Source Frequency Errors:

The 37100A's internal source is phase locked to provide synthesizer accuracy and stability during measurements. The source is phase-locked through the IF. If conditions are such that the source is not at the correct frequency, but a spurious IF is within the IF bandwidth, the 37100A may phase lock on the spurious IF. This results in the source being at the wrong frequency. For example, the desired configuration is: LO at 9.99 GHz, RF at 10 GHz, and IF at 10 MHz. If the source is initially 5 MHz off, such that the IF is at 5 MHz, the second harmonic of the IF will be at 10 MHz, and the 37100A may lock to this second harmonic. This would result in the source being 5 MHz off in frequency. This problem only exists at low IF frequencies, so the solution is to keep the IF frequency above about 50 MHz. With two external synthesizers the 37100A does not phase-lock the source, so this problem will not occur.

## APPENDIX D: Removing the Effects of Gain/Phase Mismatch in the Test System Channels

There are two ways this can be accomplished:

- Characterize the amplitude and phase offset of each test system component and combine them using an external controller.
- Measure the DUT with each channel and using an external controller, determine the amplitude and phase offset.

### Characterizing the Individual Components:

Characterizing the individual components and combining them to determine the total system effect is the traditional method of determining system error. The mismatch of the test system components are characterized at every frequency point and combined to produce the total system error.

First the power splitter and its cabling (the cables between the splitter and the DUT, including any attenuators) are characterized for each point over the RF range. This is easily accomplished with an Anritsu 372/300 VNA. Measure the  $a_1$  side with the  $b_2$  side terminated, then reverse the procedure. The ratio of  $b_2/a_1$  is the amplitude and phase mismatch of the splitter and its cables.

Next the receiver and its associated cables (the cables between the DUT and the receiver, including any attenuators) can be characterized over the IF range. This is a two step process:

- Characterize a power splitter over the IF range.
- Use the power splitter to characterize the receiver.

A power splitter (which is used only for the system characterization) is characterized in the same manner just described. This splitter is then connected to the 37100A with the RF Out of the VNA driving its input, and its outputs connected to the  $a_1$  and  $b_2$  ports. With the receiver set to measure  $b_2/a_1$  the measurement will show the total amplitude and phase mismatch, which is in fact the receiver mismatch times the splitter mismatch. If this number (receiver \* splitter) is divided by the splitter error just characterized the result is only the error of the receiver and its cables.

Now that all system components are characterized, the total system error can be calculated as:

$$\text{RF splitter error} \times \text{Receiver error} = \text{Total system error}$$

With the total system error known, it can be ratioed out of any subsequent DUT measurements.

### Measuring the DUT with Each Channel:

A more straightforward and simpler way of determining system error uses multiple DUT measurements to find the error. An amplitude and phase match measurement can be thought of as having two unknowns; the error of the DUT and the error of the system. If two sets of measurements are made, forming two sets of equations, then these two unknowns can be determined.

First measure the DUT with channel 1 connected to  $a_1$  and channel 2 connected to  $b_2$  and record the result. Then measure the DUT with channel 2 connected to  $a_1$  and channel 1 connected to  $b_2$ . The system error is then determined, as detailed below, from the formula:

$$\sqrt{(b_2/a_1)_1 * (b_2/a_1)_2} = \text{System amplitude/phase error}$$

where:  $(b_2/a_1)_1$  is the result of the first measurement  
 $(b_2/a_1)_2$  is the result of the second measurement

Once the system error is known it can be ratioed out of subsequent measurements.

If desired, the DUT difference is determined from the formula.

$$\sqrt{(b_2/a_1)_2 / (b_2/a_1)_1} = \text{DUT amplitude/phase difference}$$

$$\begin{aligned} \left(\frac{b_2}{a_1}\right)_1 &= \frac{S_{b_2}}{S_{a_1}} * \frac{\text{DUT}_1}{\text{DUT}_2} & \left(\frac{b_2}{a_1}\right)_2 &= \frac{S_{b_2}}{S_{a_1}} * \frac{\text{DUT}_2}{\text{DUT}_1} \\ \frac{\text{DUT}_1}{\text{DUT}_2} &= \frac{S_{a_1}}{S_{b_2}} * \left(\frac{b_2}{a_1}\right)_1 & \frac{\text{DUT}_1}{\text{DUT}_2} &= \frac{S_{b_2}}{S_{a_1}} * \left(\frac{a_1}{b_2}\right)_2 \\ \left(\frac{b_2}{a_1}\right)_1 * \frac{S_{a_1}}{S_{b_2}} &= \frac{S_{b_2}}{S_{a_1}} * \left(\frac{a_1}{b_2}\right)_2 \\ \left(\frac{b_2}{a_1}\right)_1 * \left(\frac{b_2}{a_1}\right)_2 &= \left(\frac{S_{b_2}}{S_{a_1}}\right)^2 \\ \sqrt{\left(\frac{b_2}{a_1}\right)_1 * \left(\frac{b_2}{a_1}\right)_2} &= \frac{S_{b_2}}{S_{a_1}} \end{aligned}$$

Where:  $\frac{S_{b_2}}{S_{a_1}}$  is the system error in the  $\frac{b_2}{a_1}$  the measurement.

DUT is the response of a channel in the converter.

## Appendix E: Measuring Absolute Mixer Parameters, without Referencing to a Golden Standard, the NxN Method

This application note describes two mixer measurement procedures; the Golden Piece method and the direct conversion loss measurement technique. The Golden Piece method measures amplitude and phase match between the Device Under Test (DUT), and a Golden Standard mixer. The accuracy of this method is wholly dependent on the accuracy of the Golden Piece data. The direct method of measuring conversion loss yields absolute magnitude but no phase information.

If absolute and accurate measurements including phase information are necessary, for applications such as phase distortion measurements, the NxN technique is the recommended method.

The NxN technique uses a standard VNA to make 12-term error corrected S-parameter measurements on a Frequency Translated Device. This method yields absolute and accurate magnitude and phase information, with measurement speeds suitable for real time tuning. Figure 8 shows the standard setup for the NxN technique. Notice that with mixer 1 down-converting the signal, and mixer 2 up-converting it back, the coherent frequency detection criterion of the VNA is preserved.

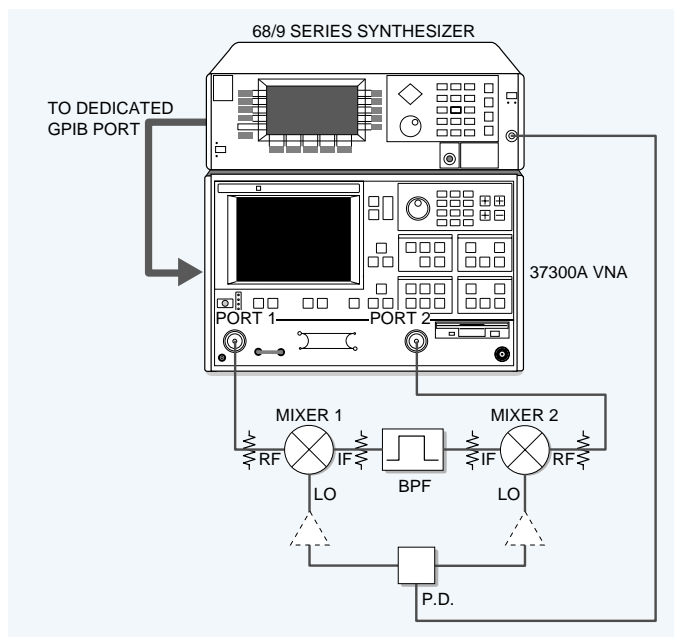

Figure 8. NxN Technique Setup

Fixed attenuators are recommended on the RF and IF side of both mixers to improve matching and reduce SWR interaction between the mixers. If enough power level is available, 6 to 10 dB attenuators should be used. In cases where excessive loss cannot be tolerated, broadband isolators may be used. The amplifiers in the LO path provide LO drive amplification, and improved LO isolation. The band pass filter in the IF path provides rejection to spurious signals from the mixers.

The Mixer 1 location in the setup is where the DUT will eventually be inserted and measured. Note that a down-converter assembly could be inserted and measured also, provided that mixer 2 properly up-converts the signal back, meeting the coherent signal detection criterion of the VNA.

Once a VNA is calibrated with standards at the end of its test port cables, the measurement reference planes are established at those two points. In order to measure the DUT at location 1, the calibration reference plane must be moved to before and after mixer 1. A software package is available that can be used for this specific calibration process. Once the calibration reference planes have been effectively moved to the desired new locations, the software package is disengaged, and the DUT is measured in location 1.

Mixer Calibration Assistant software is available to guide the user through the NxN calibration technique. The software characterizes the IF path, comprised of the two IF side attenuators and the band pass filter. The two RF side attenuators are calibrated out as part of the VNA measurement system, leaving the task of characterizing mixer 2. Using the above IF path, RF Cal, and Mixer 2 data, the software creates a new calibration file and loads it into the VNA for measurements at location 1. Specifically, the new calibration file is equal to the RF calibration including the RF attenuators, compensated for the IF path and mixer 2.

The NxN technique is used for characterizing a mixer for location 2. The technique uses a VNA to provide an inferred response from several measurements, involving the swapping of three test mixers. In particular, the technique is based on the concept of performing three sets of measurements using pair-wise combinations of three devices. The result is a set of three simultaneous equations from which the individual device responses can be determined. Once the three test mixers are characterized, either one can be chosen as the up-converting mixer in location 2.

The three mixers should have similar operating parameters, but they need not be identical from a performance standpoint. An important requirement of at least one of the three mixers is reciprocity. Since one mixer is used in both forward and reverse mode during the pair-wise combination measurements, it needs to display the same response in both configurations. Commonly used double and triple-balanced mixers exhibit this property when operated linearly with their ports terminated properly. A simple way to verify reciprocity is to check the equality of  $s_{21}$  and  $s_{12}$  of a combination of two mixers in back to back configuration.

## Calibration Process using the Mixer Calibration Assistant Software (p/n 2300-232):

Install the software on a PC running the Windows® operating system (16 or 32 bit), and containing a National Instruments GPIB board. Configure the system as shown in Figure 8 and attach the PC to the VNA GPIB port. Start the Mixer Calibration Assistant software program by double-clicking on the icon. Figure 9 shows the first screen. Use the Sys Config icon to change the GPIB address of the VNA.



Figure 9. Mixer Measurement Calibration Assistant Main Screen

The following steps are used to calibrate the VNA for a mixer measurement: Measure Filter and Interconnect, Measure Reference Mixers, and Measure DUT Mixers. The application-specific step Measure Attenuator and Amplifier must be specifically selected. Full 12-term Calibration is the only calibration that can be used with this software. Other calibrations, such as Transmission Only, are not allowed and will result in a GPIB error.

### General Warning

In order to get accurate results, the response of the calibrated components must remain constant before and after calibration. This consistency requires the utmost care during the entire process. All connections should be torqued to the manufacturers' specifications. When adapters are required, precision components are recommended. These adapters might sometimes need to be swapped due to different requirements between the calibration and DUT measurement steps. In order for the calibration to remain valid, the two different precision adapters used must be electrically interchangeable. Anritsu Calibration Kits contain different style Phase Equal Insertables (PEI) that have identical electrical length; therefore, calibrating with one and measuring with another will result in accurate measurements.

## Measure Filter and Interconnect Step:

This step characterizes the IF chain comprised of the IF attenuators, band pass filter, and any other components between the two mixers. This characterization occurs at the IF frequencies, the operating range of these components.

If we assume that the final measurement will be made at 401 data points, all calibrations and measurements must also be made at 401 data points. If the IF is a CW frequency, set the VNA to 401 data points CW measurement.

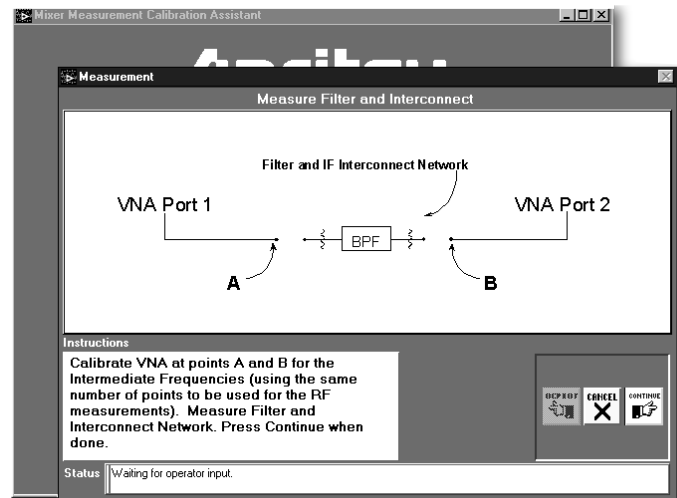

Figure 10. Measure Filter and Interconnect

The software will prompt you to calibrate the VNA appropriately, and select Continue when ready, as shown in Figure 10.

*It is important to wait until the VNA has completed a good measurement before pressing Continue. If inaccurate data is downloaded due to a rushed selection, the overall measurement accuracy will degrade significantly. Wait for two complete sweeps before pressing Continue, giving the VNA a chance to update all forward and reverse terms' coefficients. This warning is valid throughout this calibration process.*

### Measure Attenuator or Amplifier:

This is an optional step as mentioned before. Select it and press Start if needed.

This step is required when a component in the RF chain needs to be characterized separately and compensated for in the final calibration. In the normal setup where two RF attenuators are used, this step is not required. The power loss of the RF attenuators does not cause an insufficient level at port 2 of the VNA, which would result in a low measurement Signal to Noise Ratio, (SNR).

Consider a case where the final DUT is a down-converter assembly with high gain. In order to test this device, a mixer for up-converting the signal back to the original frequency is required at location 2. With a total of three of this type of mixer, the system can be calibrated and the down-converter can be measured. Due to the high gain of the DUT, significant attenuation is needed at its input. During calibration that attenuator is present in the system, but the high gain DUT is replaced with a standard lossy mixer. Without this special step, the SNR during calibration will cause degradation in measurement accuracy.

Figure 11 shows the step to characterize up to two RF chain components separately.

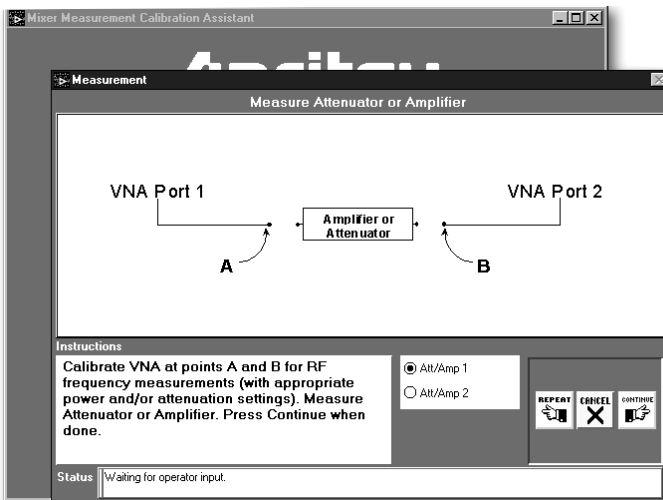

Figure 11. Measure Attenuator or Amplifier

### Measure Reference Mixers:

The software will now guide you through three measurements, in order to characterize all three mixers. Check the following table:

|                | Location #1 | Location #2 |
|----------------|-------------|-------------|
| Measurement #1 | Mixer #1    | Mixer #2    |
| Measurement #2 | Mixer #2    | Mixer #3    |
| Measurement #3 | Mixer #3    | Mixer #2    |

Labeling the three Mixers is recommended. At the completion of the characterization steps, you will be asked to select one of the three mixers as the up-converting mixer in the DUT measurements. If the selected reference mixer does not match the actual mixer inserted, the final measurement accuracy will be inaccurate.

Notice that mixer #2 is the only mixer that is used both in the forward and reverse direction. It is the only mixer that is required to exhibit the reciprocity property discussed earlier in this appendix.

Follow the instructions in the software, as shown in figure 12. The calibration in this step is performed at the RF frequencies. During the RF calibration, the RF attenuators should be installed on the VNA test port cables, and calibrated out as part of the VNA system.

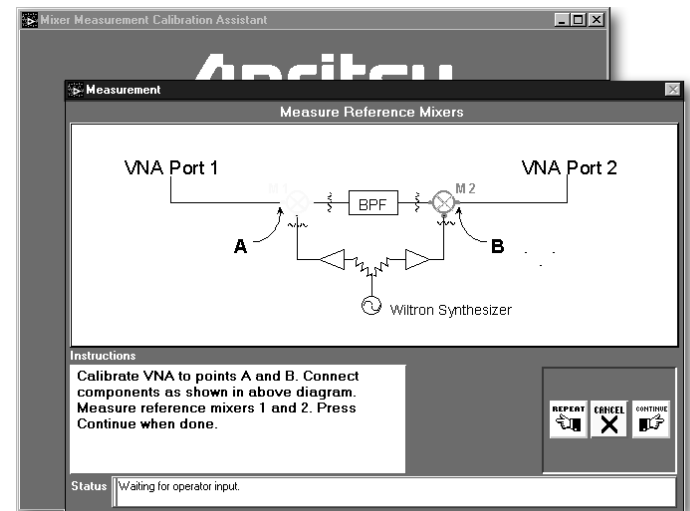

Figure 12. Measure Reference Mixers

Since the mixers are in the measurement path, the LO source now comes into play for the first time. If a fixed-LO measurement is being made, the VNA does not have to control the source. Any synthesized source may be used and controlled manually. If the VNA is asked to control the source, as is necessary in a swept-LO measurement, the source has to be a 68/9XXX series El-Toro synthesizer. Refer to Appendix A for instructions on how to use the VNA's Multiple Source Control Mode to control an external source, and set the proper RF and LO frequencies. In this case the receiver frequency equation is set equal to the RF frequency, as the VNA is not aware that a frequency translated device is being measured.

Remember to always use the same number of data points as in the previous stages, and to always wait for two full sweeps of the VNA before pressing Continue.

### Measure DUT Mixer:

This is the final step before measuring the DUT. The screen shown in Figure 13 allows the selection of one of three characterized mixers as the reference mixer to be used in location 2.

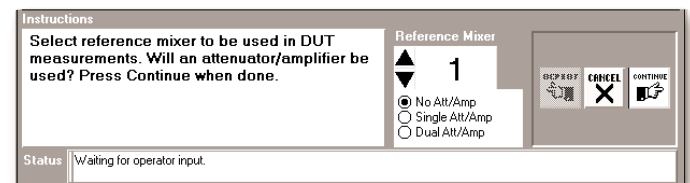

Figure 13. Choosing the Reference Mixer

At this point the software is ready to download a calibration from the VNA, compensate for the IF chain, reference mixer, and optional attenuator, and then upload a new calibration into the VNA. It will give you an opportunity to recalibrate the VNA, if the current calibration is not suitable for the software to modify. This is rarely the case, unless another power level calibration is required. Once Continue is pressed, the software displays a message that the new calibration has been successfully uploaded into the VNA, as shown in Figure 14. You may remove the PC at this point, and measure DUTs at location 1.

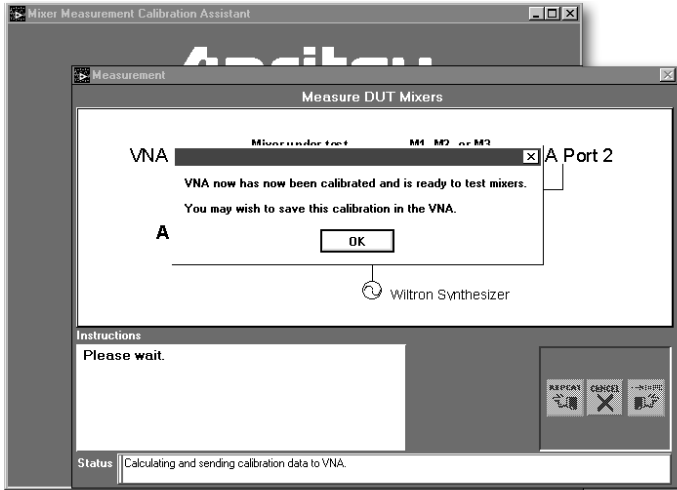

Figure 14. Perform final cal screen with cal uploaded message.

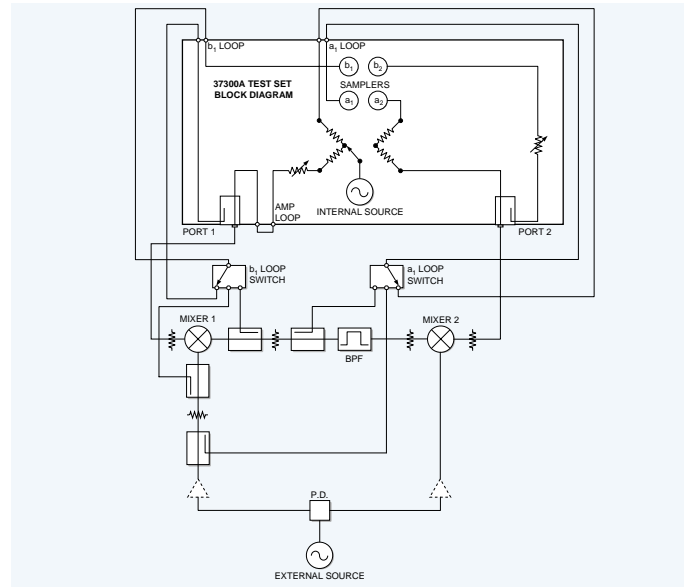

Figure 15. Adding Isolation and Match Measuring Capabilities to the NxN Measuring Technique

Figure 16 shows mixer conversion (magnitude and phase), group delay, phase linearity, and input match measurements. Custom systems that can be used for port to port isolation, and all three ports match measurements are also available from our Custom System Solution Group. A typical test set block diagram is shown in Figure 15, where back to back couplers are added in the IF and LO paths of mixer 1. For more information about custom solutions for your measurement needs please call your Anritsu representative.

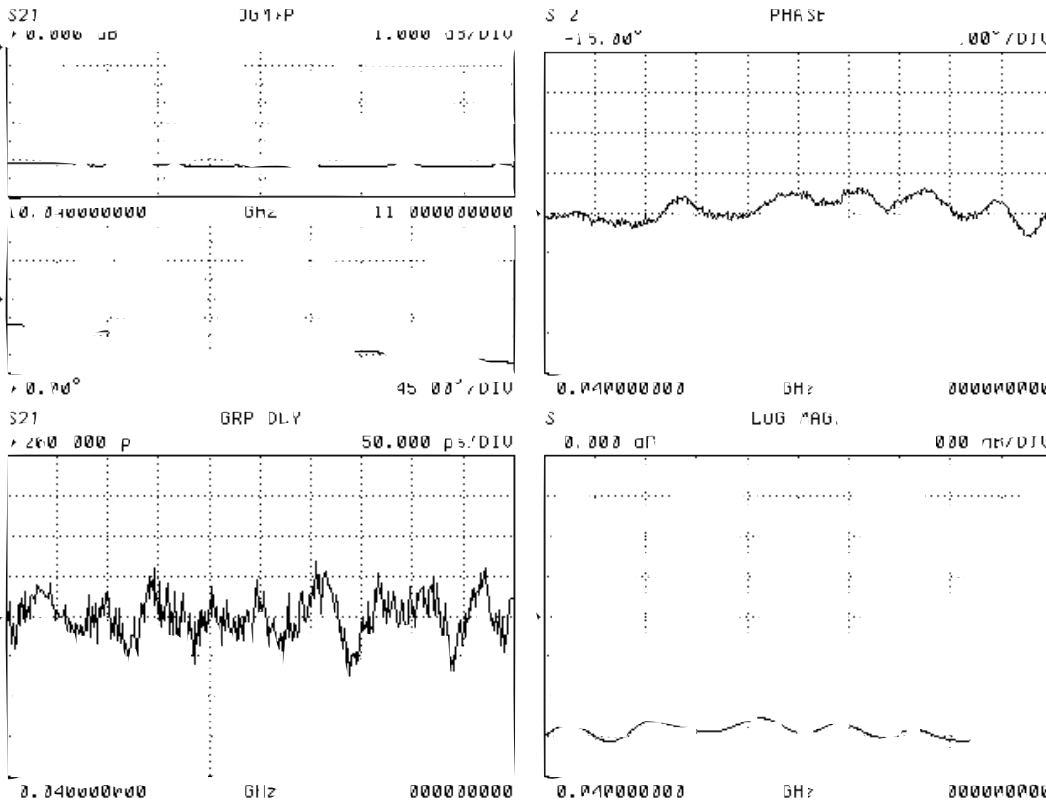

Figure 16. Typical mixer measurements after and NxN calibration.

## Appendix F: How to Apply the 37100A Material to a 37200B or 37300A Anritsu VNA

The 37100A and 37300A block diagrams are shown in Figures 1 and 9 respectively. The 37300A's reference loops in the back of the instrument allow direct access to the  $a_1$  and  $b_1$  samplers. The 37200B series does not offer the step attenuators. Only a reference loop to the  $a_1$  sampler is available as an option. However, additional reference loops on either series can be quoted as a special. The advantage of these two configurations is the ability to make S-parameter measurements without the need of an external reflectometer test set.

### Amplitude and Phase Tracking, Group Delay:

With the reference loops removed, Port 1 becomes equivalent to the 37100A RF Out port. Ports  $a_1$  and  $b_1$  will be available at the back. The equivalent setup for Amplitude and Phase Tracking, and Group Delay measurements is shown in Figure 10. Notice that the  $b_1$  port is used instead of  $b_2$ .

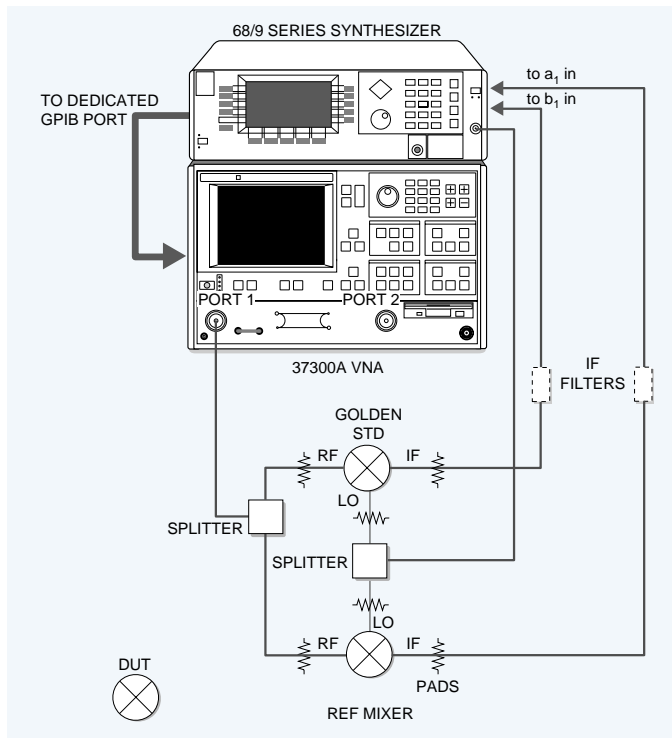

**Figure 10.** Mixer Amplitude and Phase Tracking, and Group Delay Setup using the 37300A.

### Conversion Loss:

For Conversion Loss measurements use port 1 as RF out, and feed the IF output directly into the  $a_1$  sampler at the back. When the sampler loop is removed, the second port should be properly terminated into 50 ohms.

### Reflection Coefficient, Port to Port Isolation:

In the setup shown in Figure 11, the Source 1 and Receiver frequencies are set equal. When set to the RF frequencies, the RF Port Reflection and RF to IF Isolation can be measured directly. When set to the IF frequencies the IF Port Reflection and IF to RF Isolation can be measured.

Rotating the mixer such that the LO port is connected to the VNA's port 1, will result in the LO Port Reflection, and IF to LO and LO to IF Isolations.

The 37300A has a front panel amplifier loop where an external amplifier can be inserted to properly drive the LO port of a mixer.

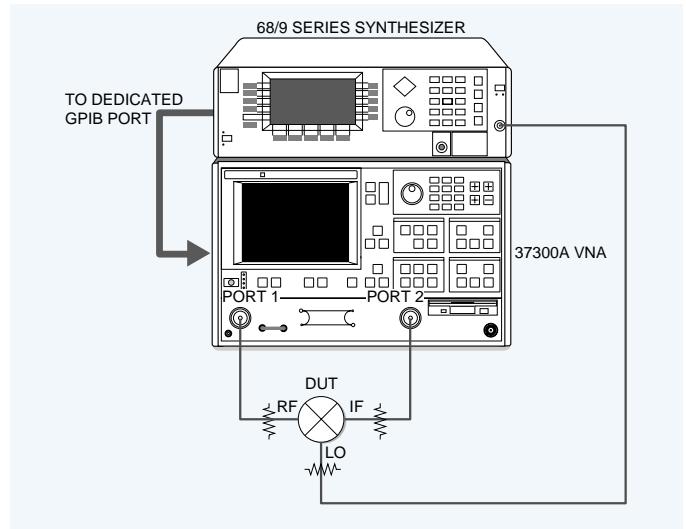

**Figure 11.** Mixer Reflection Coefficient, and Port to Port Isolation Setup using the 37300A.



*All trademarks are registered trademarks of their respective companies.*

**Sales Centers:**

United States (800) ANRITSU  
Canada (800) ANRITSU  
South America 55 (21) 286-9141

# Anritsu

Microwave Measurements Division • 490 Jarvis Drive • Morgan Hill, CA 95037-2809  
<http://www.global.anritsu.com> • FAX (408) 778-0239

**Sales Centers:**

Europe 44 (01582) 433200  
Japan 81 (03) 3446-1111  
Asia-Pacific 65-2822400