

Application Note

Pulsed S-parameter Measurements

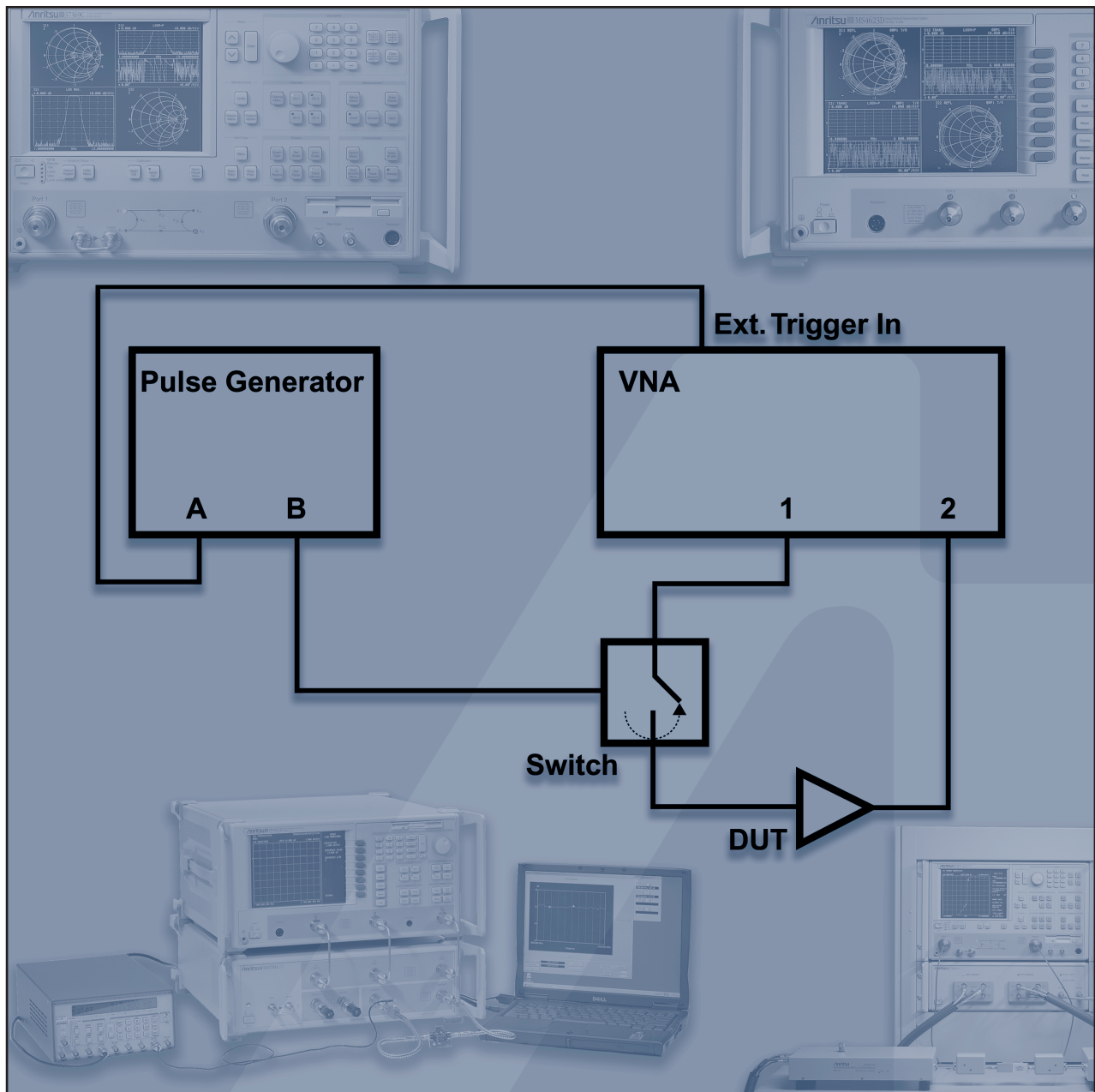

*RF, Microwave and Millimeter-Wave Measurements
for a Variety of Pulsed Conditions*

Introduction

Many devices, particularly power devices, were not designed to operate continuously or with CW signals. When devices are being tested on-wafer, this becomes even truer since thermal resistance is often greatly increased (e.g., [1]). In these cases, S-parameter measurements must often be performed in a pulsed environment.

The details of the measurement are greatly dependent on the pulse properties being studied. At one extreme is the realm of high pulse repetition frequencies (PRFs) and fairly narrow pulses as is common in radar applications. At the other extreme is the communications arena where PRFs are quite low and pulse widths fairly wide (e.g., GSM [2]). These two extremes exemplify two techniques, termed *bandwidth limited* and *triggered*, that are discussed in this note. The two approaches overlap in terms of allowed parameters to a certain degree so most situations can be covered by one if not both of them. Pulse profiling of the detailed transient response is not covered here although it is briefly discussed with regard to triggered measurements elsewhere [3]. Certain rise/fall time behaviors can be studied using time domain mode [4] but that will not be discussed either. The objective is to gain an understanding of performing general S-parameter measurements with a vector network analyzer (VNA) across a range of pulsed conditions for both RF and microwave/mm-wave measurement applications.

Background on the spectra of pulse RF signals

A pulsed RF signal will have a spectrum composed of a series of spectral lines with an envelope described by a sinc function (e.g., [5]). The spacing of the lines is set by the PRF while the envelope shape is fixed by the pulse width (assuming rise and fall times are small relative to the width). The relationship is shown in Figure 1. The 'size' of this spectrum with respect to the IF bandwidth (IFBW) of the network analyzer determines the measurement mode.

In the case of low PRF and wide pulses, the entire spectrum can fit within an IFBW. In this case, the measurement proceeds normally without a significant reduction in dynamic range. Some additional smoothing/averaging may be needed to reduce effects of the outlying portions of the distribution in Figure 1. A requirement in this measurement is that the VNA measurement be aligned in time with the pulse, hence the term *triggered*.

In the case of a high PRF, the line spacing can be substantial relative to the IFBW so the analyzer can just pick off the center line (thus the term *bandwidth limited*). The measurement of just this line is sufficient to perform an S-parameter measurement (since it carries the magnitude and phase of the envelope at the center point) as long as a calibration is performed under those same conditions. Since only a fraction of the total signal energy is used, however, the dynamic range may be limited.

Triggered measurements

Since the spectrum fits entirely in an IFBW in this case, the dependence of the measurement on the pulse train would appear simple. In the time domain sense, however, one wants the sampling to occur during the 'on' period of the pulse in order to capture the desired information. This is accomplished by triggering the VNA to measure in the appropriate points in time.

The details of this process (and applications to other measurement types) are covered in greater detail elsewhere [3] but will be summarized here.

As shown in Figure 2, the idea is for the trigger pulse to arrive at the VNA sometime before the RF pulse in order to account for instrument latency although starting later is allowed. The sampling can begin sometime after the RF pulse has settled unless that process is of interest as well. The sampling can continue for a substantial portion of the pulse but should not continue beyond the end. As a gross limit, the IFBW must be greater than $1/(\text{pulse width})$ to keep sampling from overrunning the pulse (30 kHz with averaging is preferred in the MS462xx family, see appendix). Because of pulse settling, internal filtering and some other latency issues, some safety margin is required. This will vary greatly depending on setup and may require some experimentation. If too small an IFBW is used (or with too much averaging), the trace data will become very noisy.

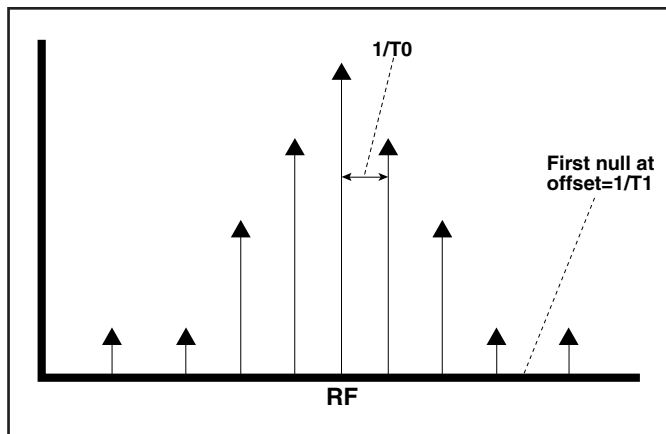

Figure 1. The spectrum of a pulsed RF signal is shown here. The center maximum is at the RF frequency, the line spacing is equal to one over the pulse period T_0 , and the first envelope null offset at one over the pulse width T_1 (neglecting rise and fall times).

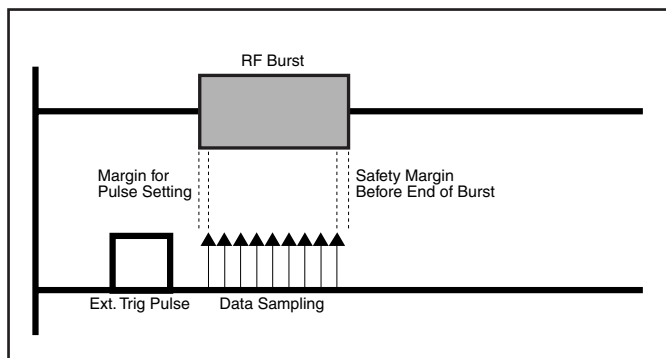

Figure 2. An illustration of the timing in a triggered measurement is shown here. The VNA is triggered sometime near the start of the pulse so that data is sampled during the pulse proper.

The pulse for the RF or the DUT control often comes from a pulse generator. The external trigger pulse can come from another channel of the same generator or it can be derived from the main pulse chain with a small delay circuit of the user's design. An example setup is shown in Figure 3. Some power level details for the various systems are given in the appendix.

There are additional limitations on the trigger frequency that can be fed to the VNA. With lower PRFs as in GSM, for example, sampling can occur on every RF pulse. With higher PRFs, it may be necessary to sample only on some pulses which may require a more elaborate timing setup. The maximum triggering frequency is dependent on the instrument, the mode, the IFBW, the frequency range, and user-intervention (button pushing or other interrupts) among other issues. To give the user some idea of maximum possible trigger rates, some limits are listed in the table below by instrument. These are not guaranteed and will vary with setup (all assume a 10 kHz IFBW, single S-parameter).

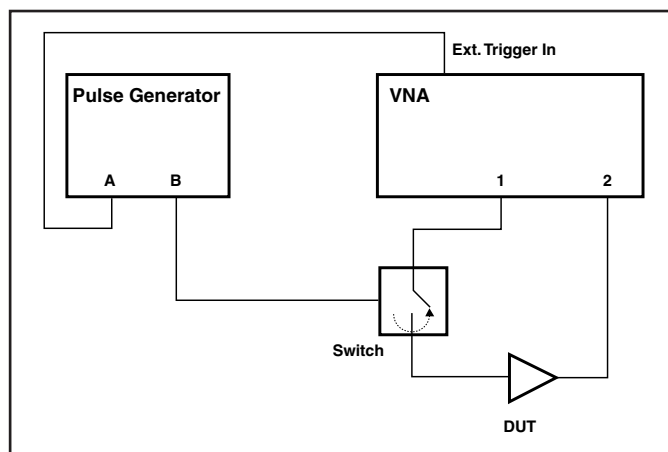

Figure 3. An example setup for a triggered measurement is shown here. A dual channel pulse generator is used to create the trigger pulse for the VNA as well as the RF pulse for the DUT. In other tests, a control line to the DUT may be pulsed instead of the RF itself.

Mode ¹	Scorpion (MS462xx) and Related Systems	Lightning (37xxx) and Related Systems
CW	Trigger rates up to 900 Hz	Up to 500 Hz
NB ² Swept	Up to 900 Hz	Up to 150 Hz
WB Swept	Up to 200 Hz	Up to 50 Hz for a 40 GHz instrument (less for 65 GHz and Panorama 110 GHz systems)

¹ Trigger width must generally be at least 50ms and is a TTL level signal. Fast CW mode (available from GPIB) allows higher rates

² NB refers to a narrowband sweep that does not include bandswitch points. Consult the factory for more details.

Example of GSM Amplifier Measurement

As a very simple example, the gain of an amplifier was measured non-pulsed and under GSM conditions at a pair of power levels. The IFBW was quite high in these examples (30 kHz) and only a frequency response (i.e., normalization) cal was performed. In the low power case, when the amplifier was far from compression, the pulsed and non-pulsed results agree reasonably well as shown in Figure 4. When the amplifier is in compression at the higher power level (0 dBm in), the results diverge as perhaps might be expected.

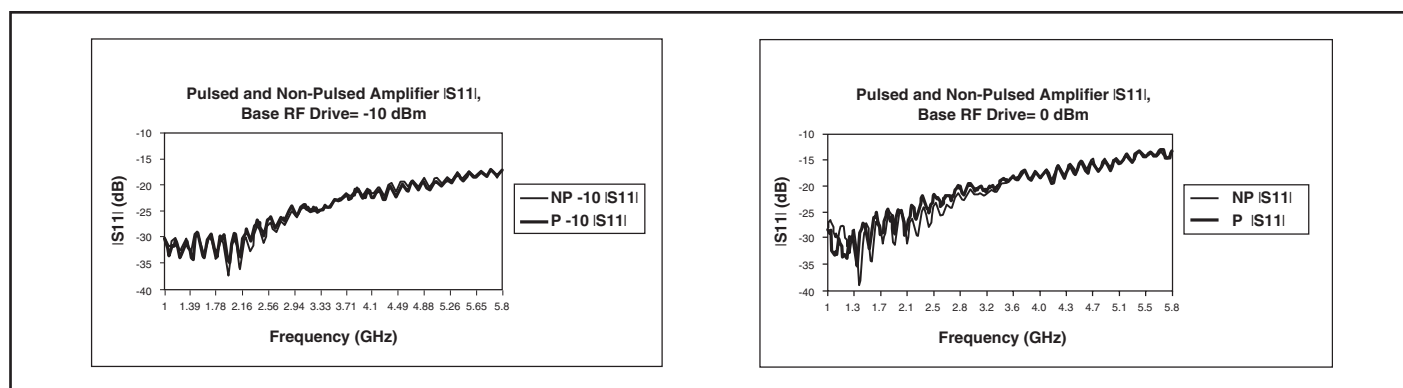

Figure 4. A comparison of pulsed (triggered under GSM conditions) and non-pulsed measurements of an amplifier is shown here. At low power levels, the results basically agree (no match correction accounts for small differences). When the amplifier is under compression, the results start to diverge.

In this measurement class, calibrations may be performed without pulsing although if a pulsing switch (as in Figure 3) is used, it should be present so its reflections and loss can be calibrated out. For full calibrations (other than just a normalization), any pulsing switch should precede the test coupler (or ideally, the reference coupler as well). In the 373xx family of VNAs, the external preamplifier loop allows one to precede the test coupler. In the MS462xx family, a direct receiver access version (MS462xC) is helpful for this and is used with the various power amplifier test systems (HATS and PATS).

Bandwidth limited measurements

In this case, the spectrum of the pulsed RF signal is very wide with respect to an IFBW. The selected IFBW must be small enough that it does not capture significant energy from other lines than the center lobe. Clearly, this technique has the most utility for PRFs of 10 kHz or higher although lower rates are allowed if the user is willing to use smaller IFBW's than the typical few kHz. An example measurement where too wide an IFBW was used is shown in Figure 5. Here the PRF was about 30 kHz and a 30 kHz IFBW was used; although this might have worked if the IF filters had perfect stop bands, this is not true in practice. Note that narrower IFBW's also have the advantage of increased dynamic range.

An important point about this technique is that a fair amount of the signal energy is thrown away by the IF filter. The signal reduction is given by

$$reduction(dB) = 20 \cdot \log_{10} \left(\frac{period}{pulse\ width} \right)$$

Thus the dynamic range will become limited as the duty cycle shrinks. For duty cycles of 1% or more, the reduction is 40 dB or less. This is usually not a problem in the MS462xx family since 90-120 dB of dynamic range is usually available originally (for narrower IFBW's). In the microwave and mm-wave VNAs, where less dynamic range is originally available, the reduction becomes more important for some measurements and duty cycles below 1% become problematic. Narrower IFBW's will enhance dynamic range in all of these limited bandwidth cases since less integrated noise is sent to the receiver.

This measurement also requires periodicity of the pulse. The triggered measurement could be more lax in this respect as long as the VNA was triggered at the right time. The bandwidth limited measurement makes assumptions about the spectral content as discussed previously so periodicity is implied.

These assumptions about spectral content also feed into the method of generating the RF pulse. It is assumed that the on/off ratio is very high so if the switching is poor (or the DUT control is not too effective), there will be additional uncertainties. While the spectral lines will not move in frequency, some of the amplitudes may change and may require a smaller IFBW than would be obvious for a quality measurement. An on/off ratio of 50 dB or better is preferred.

Example of 30 kHz PRF (duty cycle= 3%) Amplifier Measurement

As a simple measurement example, consider an amplifier to be pulsed with a PRF of 30 kHz and a duty cycle of 3%. The measurements will be made with an IFBW of 1 kHz and compared to non-pulsed measurements at a pair of power levels. A one-path two-port calibration was used to correct for input match effects. Different calibrations were needed for the pulsed and non-pulsed cases since the calibration must occur under the same signal conditions for bandwidth limited measurements. The results for pulsed and non-pulsed drives are about the same when the RF level is low as shown in Figure 6. At compressive levels, however, the results diverge. This might be expected since the average signal seen by the amplifier is quite different in the two cases.

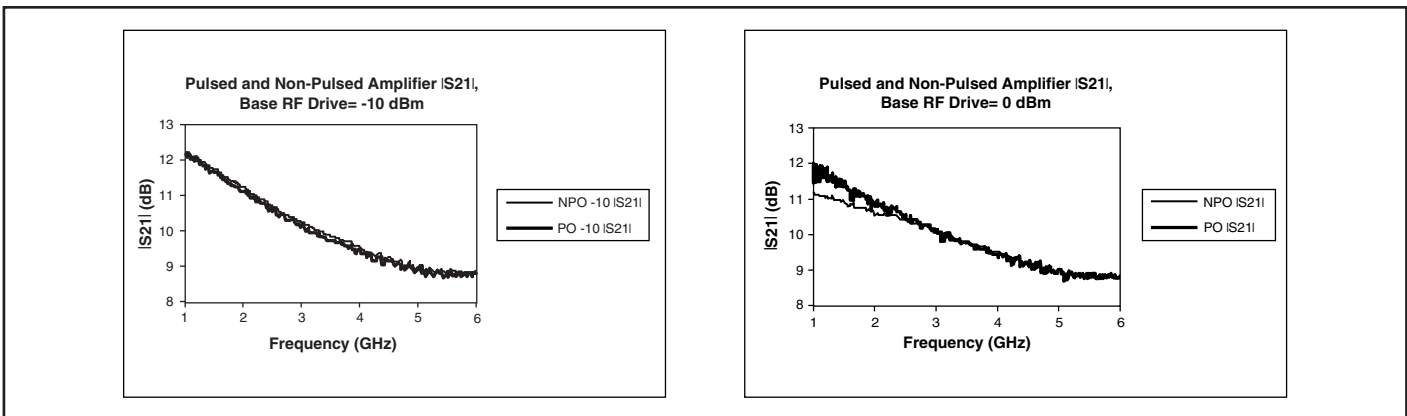

Figure 6. Bandwidth limited example measurements for an amplifier are shown here. NP denotes a non-pulsed measurement while P denotes a pulsed measurement.

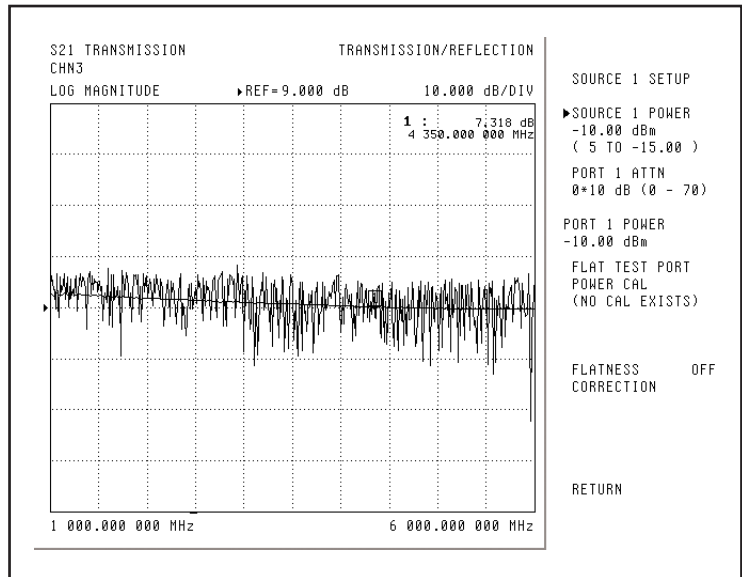

Figure 5. A bandwidth limited measurement with a PRF of 30 kHz is shown here. The flat trace represents a measurement with an IFBW of 3 kHz and is correct. The noisy, incorrect trace is a measurement with a 30 kHz IFBW in which additional spectral lines are admitted to the IF system.

In this measurement type, calibrations must be performed under the same pulsed conditions. As discussed in the previous section, any pulsing switches should precede at least the test coupler for full calibrations (other than simple normalizations). In the above example, a MS462xC direct receiver access VNA was used together with a Handset Amplifier Test System (HATS) test set.

If simple normalization calibrations are all that are desired, then the pulsing switch may be after the couplers. This was done for the example measurement in Figure 7. In this case the DUT was a simple W-band waveguide high pass filter and it was measured both pulsed and non-pulsed over approximately 71 to 80 GHz. The pulsed normalization was done with the pulsing switch in place and operating at a PRF of 10 kHz with a duty cycle of 10%. The curves agree quite well, any differences are primarily due to differences in uncorrected match in the two setups.

It is important to note the dynamic range well in excess of 40 dB evidenced by this plot. Even though the pulsing reduces the dynamic range by 20 dB (per an earlier equation) and the pulsing switch in this case only has about 50 dB of on/off ratio, there is still sufficient range to make this measurement.

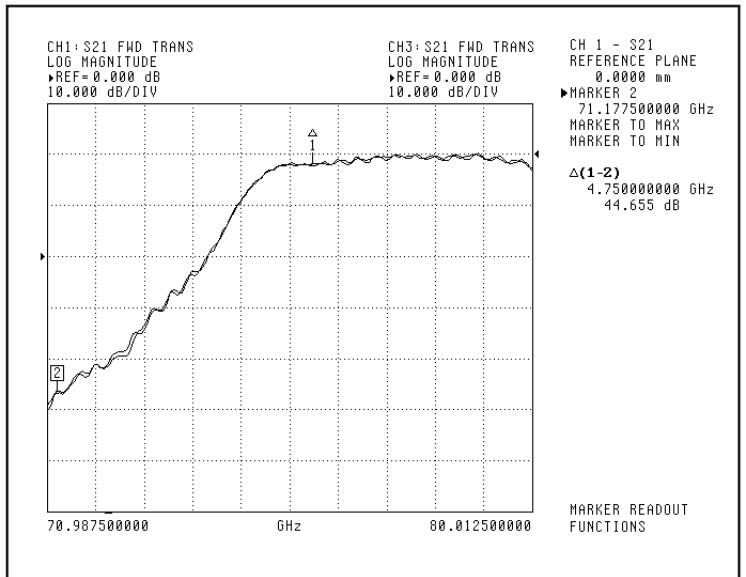

Figure 7. The results of a W-band filter measurement, pulsed and non-pulsed, are shown here. As expected for a passive device, the results agree well. Some differences are present since only a normalization cal was used and mismatches are not corrected.

Summary

Two different techniques for pulsed S-parameter measurements have been presented along with some details on how to make successful measurements. As a summary of when each of these techniques is most appropriate, a table is provided below.

	Pulse width >50 us	Duty cycle >1%	Duty cycle <1%
PRF >10 kHz	N/A	<i>BW limited</i>	BW limited (reduced DR, harder at high frequencies)
PRF 1-10 kHz	Triggered (measure on only some pulses)	BW limited (lower IFBW)	BW limited (reduced DR and lower IFBW, harder at high frequencies)
PRF <1 kHz	<i>Triggered</i>	BW limited (lower IFBW) or triggered (if duty cycle >5%)	BW limited (reduced DR and lower IFBW) difficult

The italicized entries are optimal while the other parts of the parameter space are measurable with some performance trade-offs. Note that for the BW limited applications, a narrower IFBW may be required as the PRF drops; this narrower IFBW tends to increase DR.

References

1. J. P. Teyssier, J. P. Viaud, J.J. Raoux, and R. Quere, *Fully integrated nonlinear modeling and characterization system of microwave transistors with on-wafer pulsed measurements*, IEEE MTT-S Micr. Symp. Dig., May 1995, pp. 1033-1036.
2. T. S. Rappaport, *Wireless Communications: Principles and Practice*, Prentice-Hall, 1996, chp. 10.
3. *Burst Measurements*, Microwaves and RF, to be published in 2003.
4. Anritsu Application Note, Time Domain for Vector Network Analyzers, P/N: 11410-00206 Rev. B, July 1998.
5. A. Oppenheim, A. Willsky, and I. Young, *Signals and Systems*, Prentice-Hall, 1983, chp. 4.

Appendix

External triggering:

In both the Scorpion and Lightning families, external triggering must be enabled, either from the front panel or via GPIB. The front panel paths are as follows:

Scorpion (MS462xx): Sweep (hard key)/More (soft key)/Triggers (soft key)/External (soft key)

Lightning (37xxx): Options (hard key)/Triggers (soft key)/External (soft key)

Power levels:

The instruments and their various optional test set combinations have different allowed input and output power combinations. The following summarizes what is available but these are subject to change

Instrument Configuration	Maximum Source Power	Compression Levels ¹
Base Scorpion (MS462xx) 10 MHz to 3, 6 or 9 GHz	+5 to +10 dBm (depending on model)	+10 dBm
Scorpion with HATS test set, 10 MHz to 3, 6, or 9 GHz	+12 dBm (preamplifiers are possible)	+37 dBm
Scorpion with PATS test set, selected frequency bands (200 MHz to 9 GHz)	+5 dBm (preamplifiers are possible)	+50 dBm
Lightning (37xxx) 40 MHz to 20, 40, 50 or 65 GHz	+5 to -7 dBm (depending on model preamplifiers are possible)	+30 dBm
Panorama system (ME7808), 40 MHz to 110 GHz	-10 dBm 40 MHz to 65 GHz, 0 dBm from 65 GHz to 110 GHz	+30 dBm to 65 GHz +10 dBm to 110 GHz

¹ Refer to instrument front panel or operational manual for corresponding damage levels.

Averaging and IFBW:

The two instrument families perform averaging and IF filtering functions differently and this has some timing impact, particularly in triggered measurements. In both cases, sweep-to-sweep averaging can be implemented off line which will reduce data jitter but not interfere with measurement timing.

The Lightning family uses analog IF filters and increasing settling time is allocated for narrower filters. The wider bandwidths are advised for triggered measurements. Averaging causes additional data samples to be taken at each frequency.

In the Scorpion family, IF filtering is done digitally and accomplished by taking more data samples for narrower IFBWs. It functions identically to averaging so one can compute an effective IFBW=labeled IFBW/(# of averages). In addition, in the 30 kHz setting, gain ranging is disabled which can introduce some timing anomalies when enabled. For dynamic range needs of less than 70-80 dB, 30 kHz IFBW plus some averaging will result in the most predictable timing for triggered measurements.

Notes:

All trademarks used are the property of their respective owners.

Sales Centers:

United States (800) ANRITSU
Canada (800) ANRITSU
South America 55 (21) 286-9141

Anritsu

Discover What's Possible®

Microwave Measurements Division • 490 Jarvis Drive • Morgan Hill, CA 95037-2809
<http://www.us.anritsu.com> • FAX (408) 778-0239



Sales Centers:

Europe 44 (0) 1582-433433
Japan 81 (03) 3446-1111
Asia-Pacific 65-2822400